

The BARLAP® flared joint is based on flaring the pipe 90 degrees and using the pipe faces to seal the connection with a standard ANSI gasket.

The connection is made by cold cutting the pipe square, deburring it, and slipping on an ANSI, DIN, SAE or ISO flange before the pipe is flared. After flaring, the flange is secured onto the pipe by way of a 90 degree flare. The flare is made to ANSI and DIN specifications using a hydraulic flanging machine to ensure that every flare is the same every time. Once the flange has been installed, it can be rotated, eliminating the need to field fit to account for correct flange orientation. When bolting the joint together, properly install a standard ANSI full face gasket and begin to tighten flange bolts evenly.

Our standard connection style conforms to ANSI and DIN specifications. The BARLAP® connection has only one method of attaching the flanges to the pipe which is by a 90-degree flare. All pipe sizes are flared the same way.

BARLAP® FLANGES

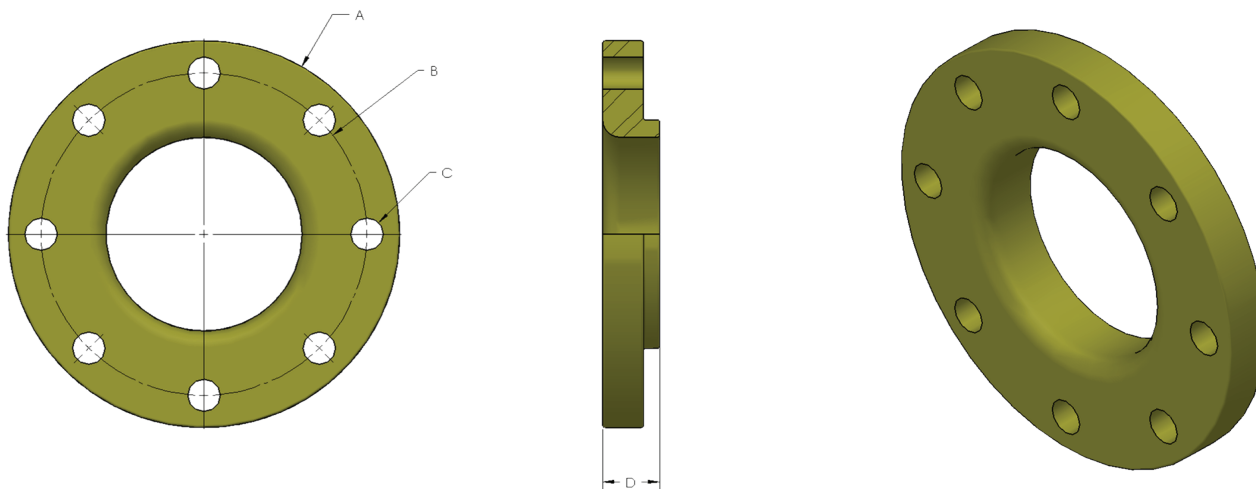

150# ANSI LAP FLANGES

Metric Pipe Size (OD x WT)	ANSI Flange Size	Part Number	Inch Dimensions				# OF BOLT HOLES	Bolt Size	TORQUE (Ft/lbs)	Weight (lbs)
			A	B	C	D				
65x5	2.5	BHBL-840-0250-**	7.00	5.50	0.750	1.125	4	5/8"	160	8
88x5	3	BHBL-848-0300-**	7.50	6.00	0.750	1.188	4	5/8"	160	9
114x6	4	BHBL-864-0400-**	9.00	7.50	0.750	1.312	8	5/8"	160	12
168x10	6	BHBL-896-0600-**	11.00	9.50	0.875	1.562	8	3/4"	280	18
219x8	8	BHBL-8128-0800-**	13.50	11.75	0.875	1.750	8	3/4"	280	28
273x9	10	BHBL-8160-1000-**	16.00	14.25	1.000	1.937	12	7/8"	460	36

** Specify flange material: CS = Carbon Steel, SS = 316 or 304 Stainless Steel

300# ANSI LAP FLANGES

Metric Pipe Size (OD x WT)	ANSI Flange Size	Part Number	Inch Dimensions				# OF BOLT HOLES	Bolt Size	TORQUE (Ft/lbs)	Weight (lbs)
			A	B	C	D				
65x5	2.5	BHBL-940-0250-**	7.50	5.88	0.875	1.500	8	3/4"	280	10
88x5	3	BHBL-948-0300-**	8.25	6.63	0.875	1.688	8	3/4"	280	15
114x6	4	BHBL-964-0400-**	10.00	7.88	0.875	1.875	8	3/4"	280	24
168x10	6	BHBL-996-0600-**	12.50	10.63	0.875	2.063	12	3/4"	280	38
219x8	8	BHBL-9128-0800-**	15.00	13.00	1.000	2.438	12	7/8"	460	55
273x9	10	BHBL-9160-1000-**	17.50	15.25	1.125	3.750	16	1"	650	88

** Specify flange material: CS = Carbon Steel, SS = 316 or 304 Stainless Steel

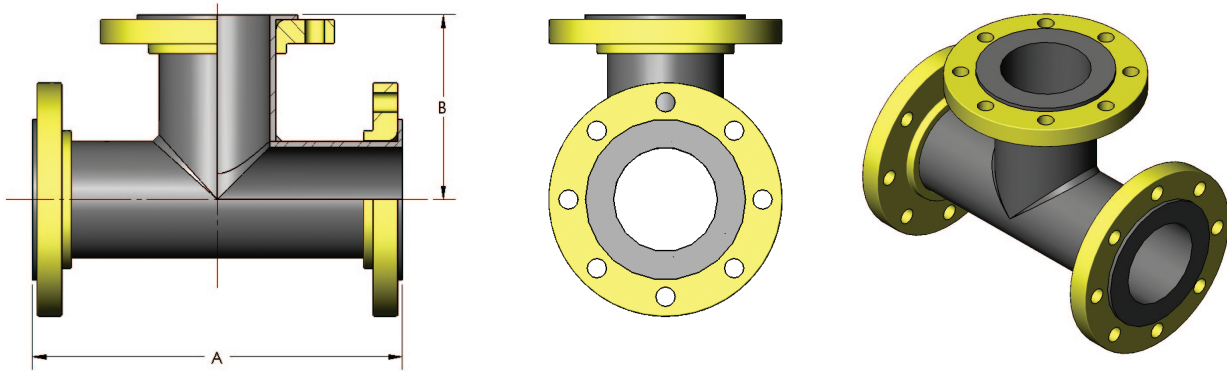

150# TEE

Nominal Pipe Size	PART NUMBER	Pipe Size (mm)	Inch Dimensions		Weight (lbs)
			A	B	
2½"	BHBL-T840-65**	65x5	11.50	5.75	35
3"	BHBL-T848-88**	88x5	12.25	6.12	38
4"	BHBL-T864-114**	114x6	14.25	7.13	56
6"	BHBL-T896-168**	168x10	18.25	9.12	98
8"	BHBL-T8128-219**	219x8	22.00	11.00	163
10"	BHBL-T8160-273**	273x9	25.00	12.50	235

** Specify flange material: CS = Carbon Steel, SS = 316 or 304 Stainless Steel

300# TEE

Nominal Pipe Size	PART NUMBER	Pipe Size (mm)	Inch Dimensions		Weight (lbs)
			A	B	
2½"	BHBL-T940-65	65x5	12.00	9.00	42
3"	BHBL-T948-88	88x5	13.00	6.50	56
4"	BHBL-T964-114	114x6	15.00	7.50	92
6"	BHBL-T996-168	168x10	19.00	9.50	158
8"	BHBL-T9128-219	219x8	22.75	11.38	245
10"	BHBL-T9160-273	273x9	26.25	13.13	498

** Specify flange material: CS = Carbon Steel, SS = 316 or 304 Stainless Steel

BARLAP® REDUCING BRANCH TEE

BAR FLARE
SYSTEM

PIPE & TUBE

CLAMPS

VALVES

ADAPTERS

HOSES &
COUPLINGS

O-RINGS

BLOCKS

TOOLING

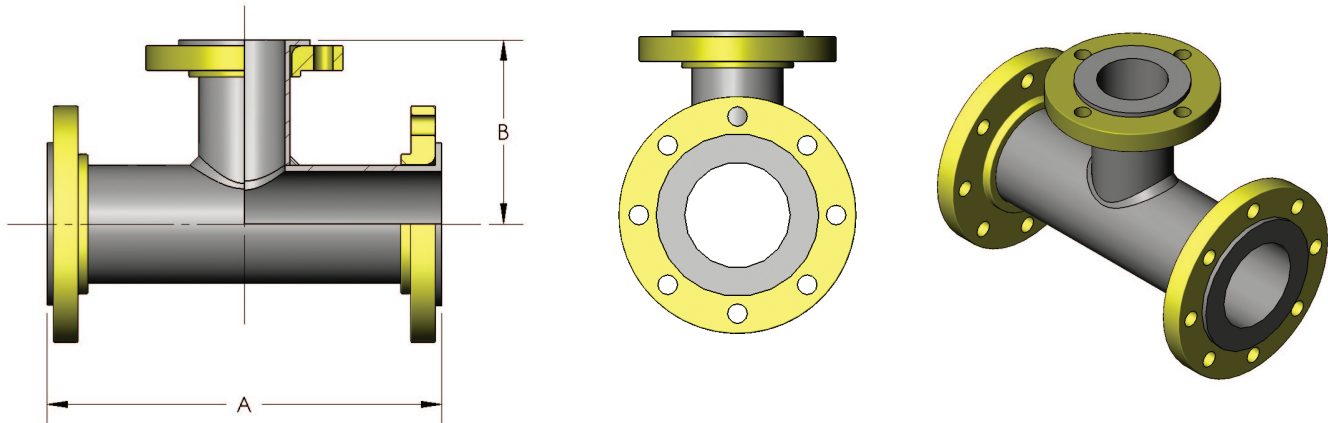

150# REDUCING BRANCH TEE

Nominal Pipe Size	Branch Pipe Size	PART NUMBER	Pipe Size (mm)	Inch Dimensions		Weight (lbs)
				A	B	
2½"	2"	BHBL-TR840-65**	65x5	11.50	5.50	35
3"	2½"	BHBL-TR848-88**	88x5	12.25	6.12	38
4"	3"	BHBL-TR864-114**	114x6	14.25	6.88	56
6"	4"	BHBL-TR896-168**	168x10	18.25	8.63	98
8"	6"	BHBL-TR8128-219**	219x8	22.00	10.50	163
10"	8"	BHBL-TR8160-273**	273x9	25.00	12.50	235

** Specify flange material: CS = Carbon Steel, SS = 316 or 304 Stainless Steel

300# REDUCING BRANCH TEE

Nominal Pipe Size	Branch Pipe Size	PART NUMBER	Pipe Size (mm)	Inch Dimensions		Weight (lbs)
				A	B	
2½"	2"	BHBL-TR940-65**	65x5	12.00	5.75	42
3"	2½"	BHBL-TR948-88**	88x5	13.00	6.38	56
4"	3"	BHBL-TR964-114**	114x6	15.00	7.50	92
6"	4"	BHBL-TR996-168**	168x10	19.00	9.00	158
8"	6"	BHBL-TR9128-219**	219x8	22.75	10.88	245
10"	8"	BHBL-TR9160-273**	273x9	26.25	12.88	498

** Specify flange material: CS = Carbon Steel, SS = 316 or 304 Stainless Steel

BARLAP® ELBOW

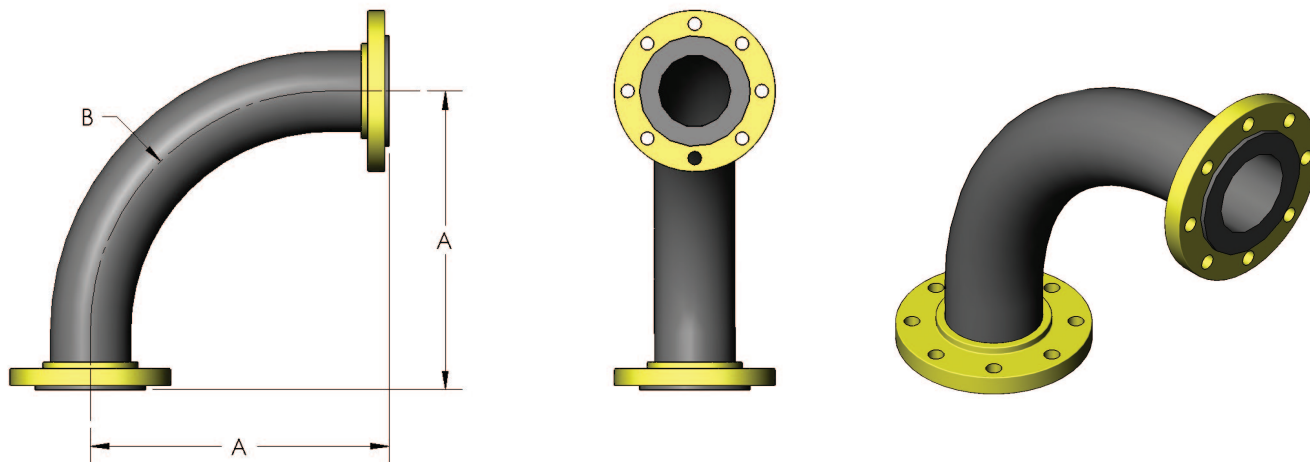

3D 150# ELBOW

Nominal Pipe Size	PART NUMBER	Pipe Size (mm)	Inch Dimensions		Weight (lbs)
			A	B (Rad.)	
2½"	BHBL-E840-65**	65x5	13.50	7.50	35
3"	BHBL-E848-88**	88x5	15.00	9.00	52
4"	BHBL-E864-114**	114x6	18.00	12.00	96
6"	BHBL-E896-168**	168x10	24.00	18.00	241
8"	BHBL-E8128-219**	219x8	30.00	24.00	311
10"	BHBL-E8160-273**	273x9	36.00	30.00	505

** Specify flange material: CS = Carbon Steel, SS = 316 or 304 Stainless Steel

3D 300# ELBOW

Nominal Pipe Size	PART NUMBER	Pipe Size (mm)	Inch Dimensions		Weight (lbs)
			A	B (Rad.)	
2½"	BHBL-E940-65**	65x5	13.50	7.50	55
3"	BHBL-E948-88**	88x5	15.00	9.00	82
4"	BHBL-E964-114**	114x6	18.00	12.00	144
6"	BHBL-E996-168**	168x10	24.00	18.00	317
8"	BHBL-E9128-219**	219x8	30.00	24.00	421
10"	BHBL-E9160-273**	273x9	36.00	30.00	681

** Specify flange material: CS = Carbon Steel, SS = 316 or 304 Stainless Steel

BARLAP® GASKETS

BAR FLARE SYSTEM

PIPE & TUBE

CLAMPS

VALVES

ADAPTERS

HOSES & COUPLINGS

O-RINGS

BLOCKS

TOOLING

150#

Nominal Pipe Size	PART NUMBER	Pipe Size (mm)
2½"	BHBL-G840-65	65x5
3"	BHBL-G848-88	88x5
4"	BHBL-G864-114	114x6
6"	BHBL-G896-168	168x10
8"	BHBL-G8128-219	219x8
10"	BHBL-G8160-273	273x9

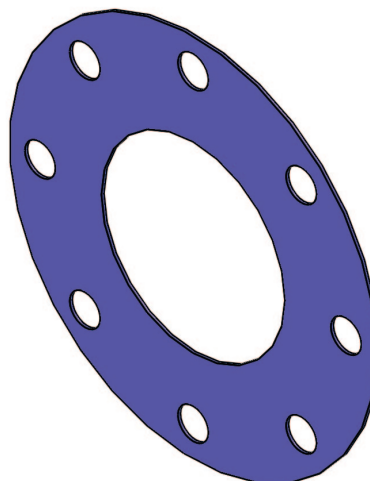

300#

Nominal Pipe Size	PART NUMBER	Pipe Size (mm)
2½"	BHBL-G940-65	65x5
3"	BHBL-G948-88	88x5
4"	BHBL-G964-114	114x6
6"	BHBL-G996-168	168x10
8"	BHBL-G9128-219	219x8
10"	BHBL-G9160-273	273x9

MATERIAL PROPERTIES

Colour:	Blue
Composition:	Aramid fibres with a nitrile binder
Fluid Services¹:	Water, aliphatic hydrocarbons, oils and gasoline
Temperature², °F (°C)	
Minimum:	-100 (-73)
Continuous Max:	+400 (+205)
Maximum:	+700 (+371)
Pressure², Max psig (bar):	1000 (70)
P x T (max.)², psig x °F (bar x °C)	
1/32 and 1/16":	350,000 (12,000)
1/8":	250,000 (8,600)
Meets Specification:	ABS (American Bureau of Shipping), WRC BS 6920 and BS 7531 Grade Y

PHYSICAL PROPERTIES

ASTM F36	Compressibility, range, %:	7 - 17
ASTM F36	Recovery, %:	50
ASTM F38	Creep Relaxation, %:	21
ASTM F152	Tensile, Across Grain, psi (N/mm²):	2250 (15)
ASTM F1315	Density, lbs./ft.³ (grams/cm³):	100 (1.60)
ASTM F433	Thermal Conductivity (K), W/m °K (BTU. ·in./hr.-ft²·°F):	0.29-0.38 (2.00-2.65)
ASTM D149	Dielectric Properties, range, volts/mil.	
	Sample Conditioning	
	3 hours at 250°F:	1/16" 396 ⁽³⁾ -832 1/8" 257 ⁽³⁾ -363
	96 hours at 100% Relative Humidity:	271 142
ASTM F586	Design Factors	
	"m" factor:	1/16" 4.2 1/8" 5.2
	"y" factor, psi (N/mm ²):	3050 (21.0) 4400 (30.3)
ASTM F104	Line Call Out:	F712102A9B4E22K5L101M5 ⁽⁴⁾

BARLAP® FLANGED PIPE ASSEMBLY

BHPALS Pipe Assembly

Complete assembly consists of:

- One (1) length of clean pipe
 - Two (2) BARLAP® flanges
 - Two (2) BARLAP® sealing cones
 - Two (2) BARLAP® gasket (if required)
 - Ends heat shrink wrapped material
- Optional steel high pressure cap or steel shipping plate

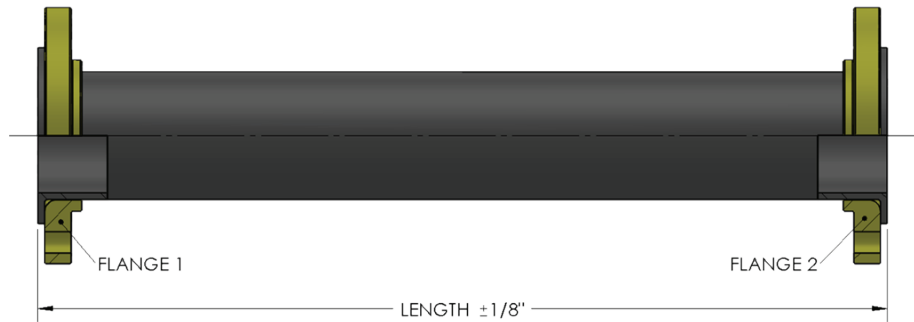

Example Part No.: BHPALS / PB — 114X6 — 864 — 864 — 196 — P

BHPALS /	Pipe Material	Pipe Size	Flange 1	Flange 2	Length	Options
----------	---------------	-----------	----------	----------	--------	---------

Material	Code
Carbon Steel (DIN 2391/St 52.4)	PB
Stainless Steel	PS

* Only available for 80mm & up

Options	
EPR	Seals for Skydrol
P	Painted (Specify)

Pipe and Flange Size	
Metric Pipe (OD x WT)	ANSI Flange Size
65 x 5	2½"
88 x 5	3"
114 x 6	4"
114 x 10	4"
114 x 15	4"
141 x 8	5"
141 x 10	5"
141 x 15	5"
168 x 10	6"
168 x 18	6"
219 x 8	8"
219 x 12.7	8"
219 x 23	8"
273 x 9	10"

Assembly Length
Specify the overall (cone face to cone face) length of assembly in inches.

Flange Type	Code
150# ANSI	8**
300# ANSI	9**

Flange Size			
Pipe Size	Code	Pipe Size	Code
2½"	*40	6"	*96
3"	*48	8"	*128
4"	*64	10"	*160
5"	*80		

** Flange size determined by selected pipe size

BAR FLARE SYSTEM

PIPE & TUBE

CLAMPS

VALVES

ADAPTERS

HOSES & COUPLINGS

O-RINGS

BLOCKS

TOOLING

BARLAP® FLANGED BENT PIPE ASSEMBLY

BHPALE Pipe Assembly

Complete assembly consists of:

- One (1) length of clean pipe
- Two (2) BARLAP® flanges
- Two (2) BARLAP® sealing cones
- Two (2) BARLAP® gasket (if required)
- Ends heat shrink wrapped material

Optional steel high pressure cap or steel shipping plate

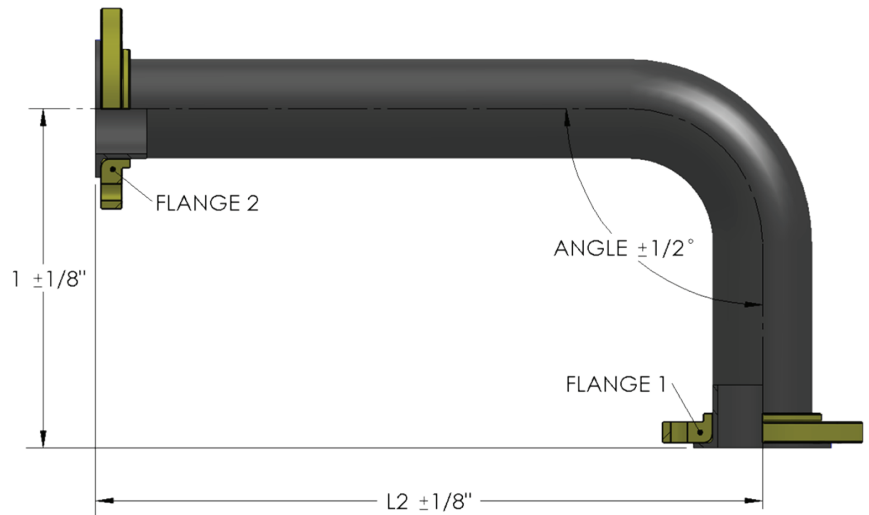

Example Part No.: BHPALE / PB - 114X6 - 864 - 864 - 83 - 193 - 90 - P

BHPALE /	Pipe Material	Pipe Size	Flange 1	Flange 2	Length 1 (L1)	Length 2 (L2)	Angle	Options
----------	---------------	-----------	----------	----------	---------------	---------------	-------	---------

Material	Code
Carbon Steel (DIN 2391/St 52.4)	PB
Stainless Steel (EN 10305-1)	PS

* Only available for 80mm & up

Options	
EPR	Seals for Skydrol
P	Painted (Specify)

Pipe and Flange Size	
Metric Pipe (OD x WT)	ANSI Flange Size
65 x 5	2½"
88 x 5	3"
114 x 6	4"
114 x 10	4"
114 x 15	4"
141 x 8	5"
141 x 10	5"
141 x 15	5"
168 x 10	6"
168 x 18	6"
219 x 8	8"
219 x 12.7	8"
219 x 23	8"
273 x 9	10"

Angle
Specify angle of bend in degrees. Max bend = 90°

Assembly Length
Specify the overall (cone face to cone face) length of assembly in inches.

Flange Type	Code
150# ANSI	8**
300# ANSI	9**

Flange Size			
Pipe Size	Code	Pipe Size	Code
2½"	*40	6"	*96
3"	*48	8"	*128
4"	*64	10"	*160
5"	*80		

** Flange size determined by selected pipe size